

# **HARSH TRACTOR / WET KIT**





## **CAB BACK OR SIDE MOUNT TANKS**





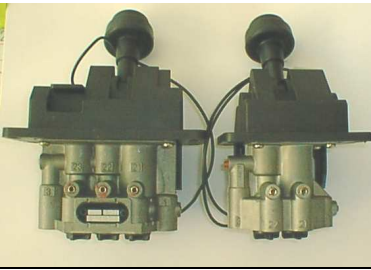
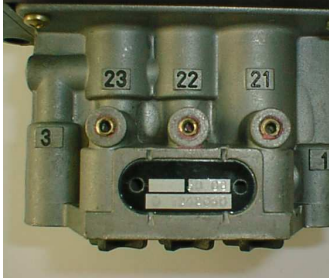

### **INSTALLATION MANUAL**

**&**

### **PARTS MANUAL**

## HARSH WET KIT – CAB BACK TANK ASSEMBLY AND INSTALLATION GUIDELINES

<p>Your wet kit parts will be supplied to you in kit form to suit the type of tractor unit it is required for. The kit packing list will be attached to the top of the box. This should be checked against the contents of the box before fitting takes place.</p>			
<p>The first job when fitting your harsh wet kit is to remove all chassis obstructions i.e the cat walk and 'a' frame. Then you should install the cab control lever. Take the air lines supplied in your air parts pack. Tape together the 3 pipes but leave a minimum of about 6 1/2' of the clear / white air line free. This is the p.t.o line. Start attaching the 3 air lines to the rest of the pipe and wire loom of the chassis. Be sure to attach the air lines from where the p.t.o line joins up with the other 2 lines. They should start being attached from where the p.t.o and pump bolts to the gear box.</p>			
<p>A suitable air supply should be located to enable the PTO engagement switch and cab control to be installed (the bodybuilder guideline booklet for your particular chassis will give a air location point).</p>			
<p>The cab control should be positioned to customer specifications, if non are given it must be easily accessible, but <b>must not</b> obstruct the drivers entrance and exit to the vehicle and also must not be located where possible knee or other injuries could occur. Ensure clearance on all areas of seating inc. height adjustment seats.</p>			
<p>The control switch should be piped up as follows to ensure correct operation.</p> <table style="width: 100%; border: none;"> <tr> <td style="width: 50%; vertical-align: top;"> <p>Single; port 1 = air in port 3 = exhaust port 21 = lower port 22 = raise</p> </td> <td style="width: 50%; vertical-align: top;"> <p>dual; port 1 = air in port 3 = exhaust port 21 = lower port 22 = raise port 23 = pto</p> </td> </tr> </table> 	<p>Single; port 1 = air in port 3 = exhaust port 21 = lower port 22 = raise</p>	<p>dual; port 1 = air in port 3 = exhaust port 21 = lower port 22 = raise port 23 = pto</p>	
<p>Single; port 1 = air in port 3 = exhaust port 21 = lower port 22 = raise</p>	<p>dual; port 1 = air in port 3 = exhaust port 21 = lower port 22 = raise port 23 = pto</p>		
<p>Before fitting the p.t.o and pump you should check them against the paper work and also check the gearbox in the vehicle is the same as that listed. The p.t.o will have it's own mounting instructions . The pump should be fitted so it is clear of the propshaft and the pipe fitting adapters are on the left and right hand side.</p>			

<p>The mounting brackets for the tank should be mounted in the same place and the same height on both sides of the chassis. If needed the brackets may have to be cut into different shapes so that they fit round obstructions on the side of the chassis i.e diesel tank brackets and the battery box brackets.</p>	
<p>The valve is mounted on the mounting block on the side of the tank. It is bolted into position using the 4 cap screws provided in the kit. Be sure to tighten the screws to no more than 20nm.</p>	
<p>The valve ports will be marked with the following references. A = pressure to rams. B = will be blank. P = pressure from the pump. T = tank return.</p>	
<p>When mounting the tank make sure you have fitted the suction adapter on it's underside first. Place the tank on the mounting brackets and check it for squareness and check that both sides are equal distances from the edge of the brackets. Clamp the tank down and drill 4 , 1/2" holes on each corner. Bolt the tank down using the 4 bolts , washers and locknuts provided in the kit.</p>	
<p>To remount the 'a' frame , 2 small brackets will be required. These should be made from angle bar and fastened to the tank mounting brackets. The 'a' frame should be as close to the tank as possible.</p>	
<p>Connect the p.t.o line to the p.t.o via the air fitting supplied and the blue and red air lines to the valve. (these are the tip and lower lines) Connect the hoses from the pump to the valve and from the pump to the tank. Do this by measuring the distances between the fittings and cut the hoses to length making sure that any bends are natural curves. The hoses and air lines should form a tidy bundle when they are all strapped together.</p>	
<p>The pressure hose should be wrapped in spiraband if possible. This helps to protect it as it sits underneath the truck and could be easily damaged as it is in motion.</p>	

The feed hose pushes onto 2 suction fittings. One is on the underside of the tank and the other is on the pump. It is held in place by 4 jubilee clips , 2 on each end. These are provided in the kit. Ensure adequate hose clamps are used to support the hoses.



Replace the catwalks and fasten the flexastick and male dummy coupling to it. Fasten the trailer coupling hose to the appropriate place on the valve. The valve will be labelled accordingly. Take the hose to the bottom of the flexastick . Cable tie it until you reach the top of the flexastick. Put the hose through the hoop and loop it round to connect up with the male dummy coupling.



Your wetkit is now complete. Fill the tank with hydraulic oil and test the system by putting the p.t.o in gear and moving the control switch into the tip and lower positions. ( only carry out the test with the coupling end removed and the pipe in an oil drum or in tank filler )  
Check all the hose fittings for any leaks , and make sure everything is correctly tightened. Re-fill with oil as required. Instructions on how to put the p.t.o in gear are provided in the kit.



**Final checks;**

**Once the system is complete it is essential to re-check the following points**

- 1) Ensure tank straps and brackets are tight.**
- 2) Ensure “a” frame or any removed items are re-installed.**
- 3) Re-check all hoses are fully tightened and adequately clamped.**
- 4) Ensure all operation stickers are fitted in the cab and warning signs are clearly visible.**
- 5) Ensure fitting and maintenance manual is placed along with warranty and ce documents in the cab for the operator.**

Harsh ltd has a policy of continuous improvement and therefore reserves the right at any time without notice to change the supply origin, price and specification of any products supplied by it. Any prices, descriptions or other data relating to any products supplied by harsh ltd are given in good faith but harsh ltd shall have no liability of any nature should there be any discrepancy between any products supplied and prices, descriptions or data.

If further general technical information is required consult the tipping gear and mounting guidelines booklet available at [www.harshtechical.com](http://www.harshtechical.com) or alternatively call our technical department on 01759 372100.

## PIPING LAYOUT FOR STANDARD WETKIT

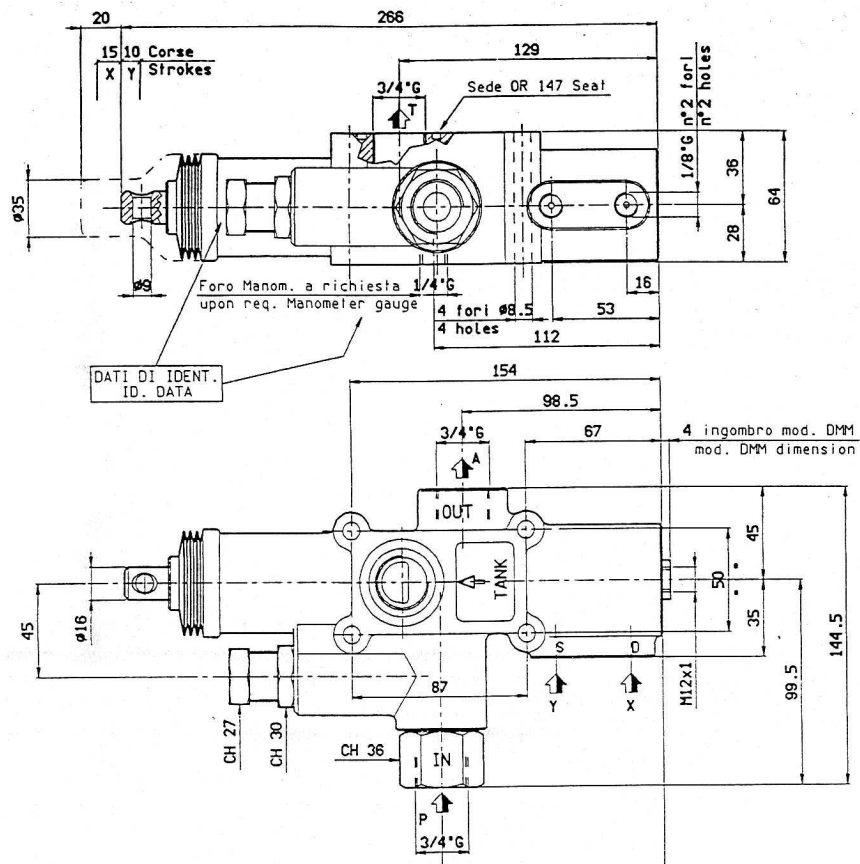
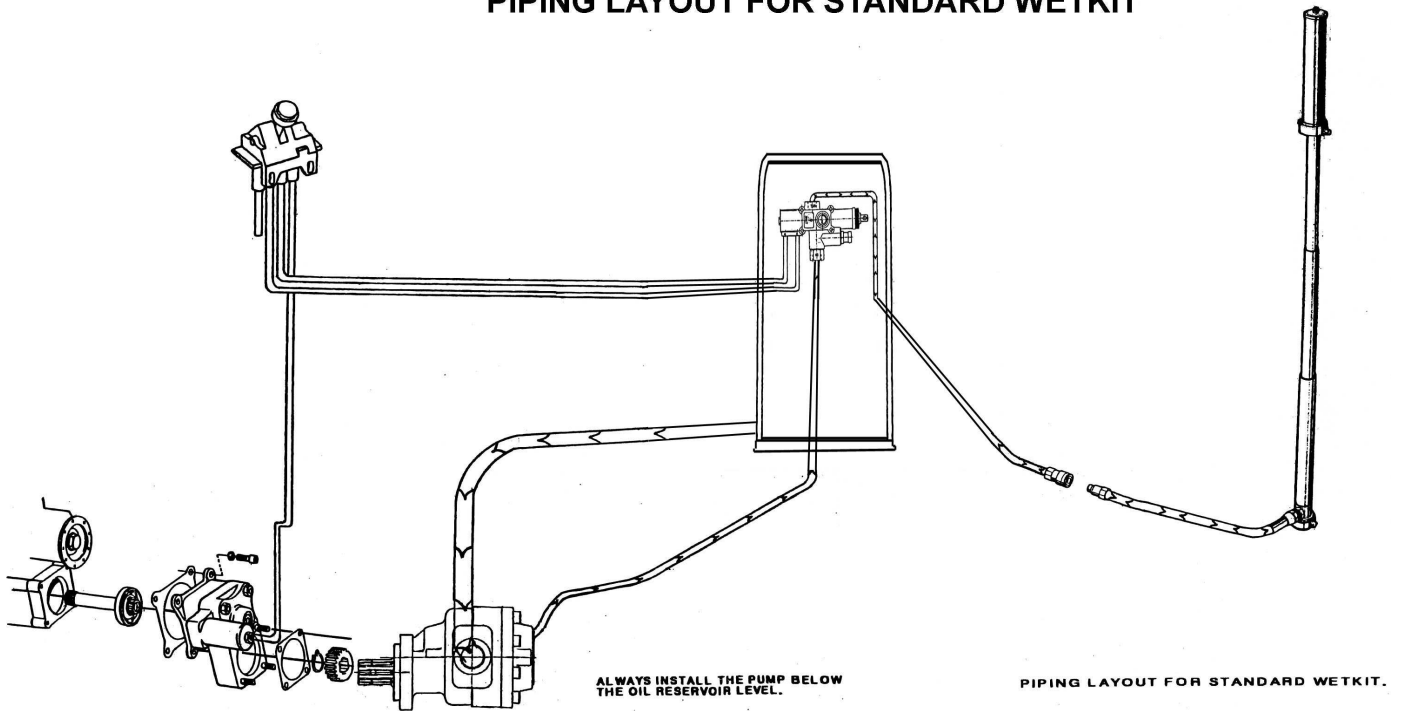

# M A I N T E N A N C E I N S T R U C T I O N

Periodic maintenance and inspection will increase the working life of the tipping hoist. Follow the routine of the check list set out below at least **once per week** or every **50 cycles** whichever ever is sooner to ensure efficiency and safety of the tipping gear.

**Liberal**ly grease all grease points on the tipping gear and rear hinge.

Check all high pressure pipes and connections for oil leaks.

Check oil level in tank when tipping hoist is at rest. Top up if necessary using the following:-

Recommend hydraulic oil:- elf - hydrelf 68. Morris - triad hv37a. Texaco - rando hd268. Shell - tellus 68.

Check fixing bolts for damage and tightness.

Check vehicle for any form of damage or wear and take measures to fully repair or replace damage on the vehicle.

Replace any damaged tipping gear parts immediately with genuine harsh replacements.

## S A F E T Y I N S T R U C T I O N

### While tipping.

Always check for overhead wires, obstructions and make sure that no other people are in the vicinity of the vehicle or tipping area before tipping.

Tip with the vehicle at rest , on level ground and with a balanced even load.  
(never overload, or heap the load).

Always check the conditions of the area where tipping i.e. Do not tip when there is:

Wet or unstable ground which may collapse or in high winds.

Stay in cab when tipping. If the load sticks or any problems develop immediately lower the body. (never shunt load free or leave cab and go under a raised loaded body.)

After tipping, always lower the body fully before driving off and disengage pto.

### While working on vehicle.

Never work under a raised loaded body even if propped.

Never work under a raised empty body unless propped.

Look for any signs of wear not only on the tipping gear but also the wood packers, hinge assembly, hoses, valve and tank assembly.

**NEVER ALLOW ANYONE UNDER AN UNPROPPED BODY**

# THE HARSH RIGID LIFT HOIST 3-YEAR LIMITED WARRANTY

HARSH LTD. warrants each new HARSH Hydraulic Tipping Gear main frame assembly to be free from defects in material and workmanship for a period of three years from the date of *despatch*. Harsh Ltd. warrants the hydraulic cylinders to be free from defect in material and workmanship for a period of one year. This warranty is expressly made to the *Original Owner* and is limited to the *Original Chassis* upon which the HARSH Rigid Lift Tipping Gear is installed.

Warranties do not extend to any Tipping Gear unit or part thereof which has been subjected to misuse, neglect, accident, improper installation, or loading over and above the recommended weight range. This warranty does not extend to such tipping gear units or parts which have been repaired or altered outside of our Factory, or to which any accessories other than HARSH have been affixed, or to any Tipping Gear not installed by an authorised HARSH Dealer or Distributor.

Harsh Ltd.'s obligation under this warranty is limited to replacement or repair of any part or parts thereof, which within the warranty period shall be returned to our factory, at Full Sutton, transportation charges pre-paid, for inspection. If such inspection reveals that a defect in material or manufacturing actually exists, then Harsh Ltd., at its option, may repair or replace the defective part. All items not manufactured at Harsh Ltd.'s Full Sutton base are subject to the original manufacturer's warranty.

This warranty is not valid until the warranty validation certificate form (which is attached and provided at the time of purchase and installation) is completed by the purchaser and returned to Harsh Ltd. Harsh Ltd. does not assign to any of its Dealers, Distributors, or Agents the right of warranty on its behalf. If said Dealer or Distributor in performing a service or repair, returns to our factory on behalf of the purchaser such parts or tipping gear the existence, validity or applicability of this warranty regarding such part or tipping gear remains solely the prerogative of Harsh Ltd. and not its aforementioned Agents. HARSH tipping gear units are intended to be used on trucks dumping from firm and level ground. Use of the tipping gear for purposes not recommended is at the purchaser's own risk. Any use of the tipping gear for a purpose or in a manner contrary to the recommendations set forth above in these paragraphs shall void the provisions of this warranty.

This warranty goes into effect on the above units installed 1/8/88 or later.

**Harsh Ltd.**  
**The Industrial Estate**  
**Full Sutton,**  
**York YO4 1HS**

7-1-87 **Retain this part of form for your records. Mail lower part of form to Harsh Ltd. as per instructions.**

## HARSH WARRANTY VALIDATION CERTIFICATE

**TO VALIDATE YOUR WARRANTY:** Complete this form and return it to Harsh Ltd. at the above address.

**NOTE:** Failure to complete and return this form within 30 days from date of installation as prescribed invalidates any warranty obligation by Harsh Ltd.

YOUR NAME & ADDRESS.....  
 ..... Tel. No. ....

HARSH DEALER'S NAME & ADDRESS .....

TIPPING GEAR MODEL..... SERIAL NO. ....

TRUCK CHASSIS MODEL ..... CHASSIS SERIAL NO. ....

DATE INSTALLED ..... INSTALLED BY .....

HOW DID YOU FIND OUT ABOUT HARSH PRODUCTS?

Magazine  Mail  Harsh Owner  Exhibition  Body Builder  Truck Dealer  Other (please state) .....

TYPE OF USAGE ..... COMMODITIES HAULED .....

CONDITION AND / OR APPEARANCE WHEN PURCHASED .....

BODY USED: MFG NAME ..... LENGTH ..... SIDE HEIGHT .....







PRICE PAID FOR TIPPING GEAR ..... PRICE PAID FOR INSTALLATION .....





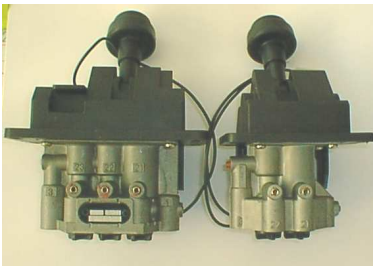

OTHER REMARKS .....

*I have read and fully understand the provisions and limitations of this warranty as outlined above.*

SIGNED ..... DATE .....

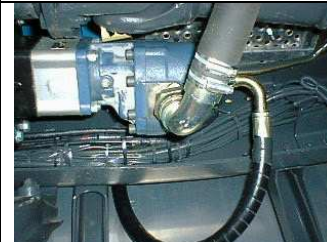
## HARSH WET KIT – SIDE MOUNT TANK ASSEMBLY AND INSTALLATION GUIDELINES

<p>Your Wet Kit parts will be supplied to you in kit form to suit the type of Tractor Unit it is required for. The kit packing list will be attached to the top of the box. This should be checked against the contents of the box before fitting takes place.</p>			
<p>The first job when fitting your harsh wet kit is to remove all chassis obstructions i.e. the cat walk and 'a' frame. Then you should install the cab control lever. Take the air lines supplied in your air parts pack. Tape together the 3 pipes but leave a minimum of about 61/2' of the clear/white air line free. This is the p.t.o line. Start attaching the 3 air lines to the rest of the pipe and wire loom of the chassis. Be sure to attach the air lines from where the p.t.o line joins up with the other 2 lines. They should start being attached from where the p.t.o and pump bolts to the gear box.</p>			
<p>A suitable air supply should be located to enable the PTO engagement switch and cab control to be installed (the bodybuilder guideline booklet for your particular chassis will give a air location point).</p>			
<p>The cab control should be positioned to customer specifications, if non are given it must be easily accessible, but <b>must not</b> obstruct the drivers entrance and exit to the vehicle and also must not be located where possible knee or other injuries could occur. Ensure clearance on all areas of seating inc. height adjustment seats.</p>			
<p>The control switch should be piped up as follows to ensure correct operation.</p> <table style="width: 100%; border: none;"> <tr> <td style="width: 50%; vertical-align: top;"> <p>Single; Port 1 = air in Port 3 = exhaust Port 21 = lower Port 22 = raise</p> </td> <td style="width: 50%; vertical-align: top;"> <p>Dual; Port 1 = air in Port 3 = exhaust Port 21 = lower Port 22 = raise Port 23 = P T O</p> </td> </tr> </table> 	<p>Single; Port 1 = air in Port 3 = exhaust Port 21 = lower Port 22 = raise</p>	<p>Dual; Port 1 = air in Port 3 = exhaust Port 21 = lower Port 22 = raise Port 23 = P T O</p>	
<p>Single; Port 1 = air in Port 3 = exhaust Port 21 = lower Port 22 = raise</p>	<p>Dual; Port 1 = air in Port 3 = exhaust Port 21 = lower Port 22 = raise Port 23 = P T O</p>		
<p>Before fitting the p.t.o and pump you should check them against the paper work and also check the gearbox in the vehicle is the same as that listed. The p.t.o will have it's own mounting instructions . The pump should be fitted so it is clear of the propshaft and the pipe fitting adapters are on the left and right hand side.</p>			
<p>The valve is mounted on the mounting block on the side of the tank. It is bolted into position using the 4 cap screws provided in the kit. Be sure to tighten the screws to no more than 20NM. If mounting to an aluminium tank a valve bracket will be provided.</p>			

<p>When mounting the tank make sure you have fitted the suction adapter on it's outlet first. Choose an appropriate position on the side of the chassis for the tank to go. Remove all obstructions before marking out the holes that need to be drilled for the tank brackets. This includes the removal of unwanted bolts and rivet studs. The tank will need to be removed from it's holding brackets before they can be mounted on the chassis. Bolt the brackets to the chassis using 4 bolts, washers and locknuts provided in the kit. Refit the tank to it's brackets once they are correctly fitted to the chassis.</p>	
<p>Connect the p.t.o line to the p.t.o via the air fitting supplied and the blue and red air lines to the valve. (these are the tip and lower lines) Connect the hoses from the pump to the valve and from the pump to the tank. Do this by measuring the distances between the fittings and cut the hoses to length making sure that any bends are natural curves.</p>	
<p>The valve ports will be marked with the following references. A = Pressure to rams. B = Will be blank. P = Pressure from the pump. T = Tank return.</p>	
<p>The pressure hose should be wrapped in spiraband if possible. This helps to protect it.</p>	
<p>The feed hose pushes onto 2 suction fittings. One is on the underside of the tank and the other is on the pump. It is held in place by 4 jubilee clips , 2 on each end. These are provided in the kit. Ensure adequate hose clamps are used to support the hoses.</p>	
<p>Replace any removed equipment and reconnect all it's fittings. Replace the catwalks and fasten the flexastick and male dummy coupling to it. Fasten the trailer coupling hose to the appropriate place on the valve. The valve will be labelled accordingly. Take the hose to the bottom of the flexastick . Cable tie it until you reach the top of the flexastick. Put the hose through the hoop and loop it round to connect up with the male dummy coupling.</p>	
<p>Your WETKIT is now complete. Fill the tank with hydraulic oil and test the system by putting the P.T.O in gear and moving the control switch into the tip and lower positions. Check all the hose fittings for any leaks and make sure everything is correctly tightened.</p>	

**FINAL CHECKS:**

**ONCE THE SYSTEM IS COMPLETE IT IS ESSENTIAL TO RE-CHECK THE FOLLOWING POINTS.**

- 1) ENSURE TANK STRAPS AND BRACKETS ARE TIGHT.**
- 2) ENSURE “A” FRAME OR ANY REMOVED ITEMS ARE RE-INSTALLED.**
- 3) RE-CHECK ALL HOSES ARE FULLY TIGHTENED AND ADEQUATLY CLAMPED.**
- 4) ENSURE ALL OPERATION STICKERS ARE FITTED IN THE CAB AND WARNING SIGNS ARE VISIBLE.**
- 5) ENSURE FITTING AND MAINTAINANCE MANUAL IS PLACED ALONG WITH WARRANTY AND CE DOCUMENTS IN THE CAB FOR THE OPERATOR.**

HARSH LTD has a policy of continuous improvement and therefore reserves the right at any time without notice to change the supply origin, price and specification of any products supplied by it. Any prices, descriptions or other data relating to any products supplied by HARSH LTD are given in good faith but HARSH LTD shall have no liability of any nature should there be any discrepancy between any products supplied and prices, descriptions or data.

If further general technical information is required consult the tipping gear and mounting guidelines booklet available at [WWW.harshtechnical.COM](http://WWW.harshtechnical.COM) or alternatively call our technical department on 01759 372100.



## PIPING LAYOUT FOR STANDARD WETKIT

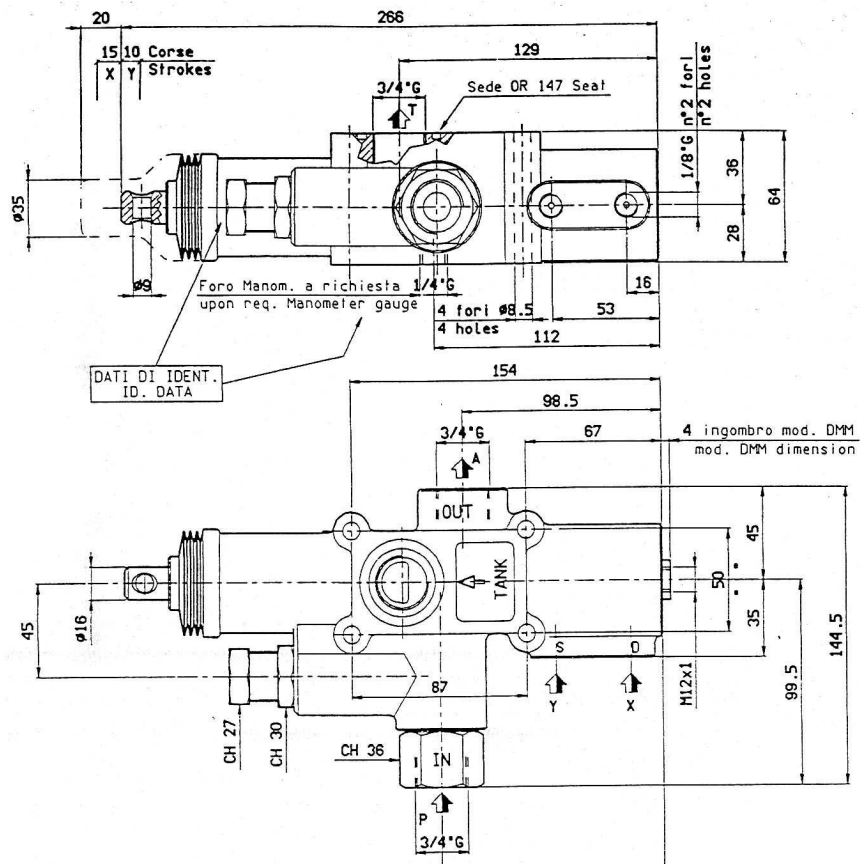
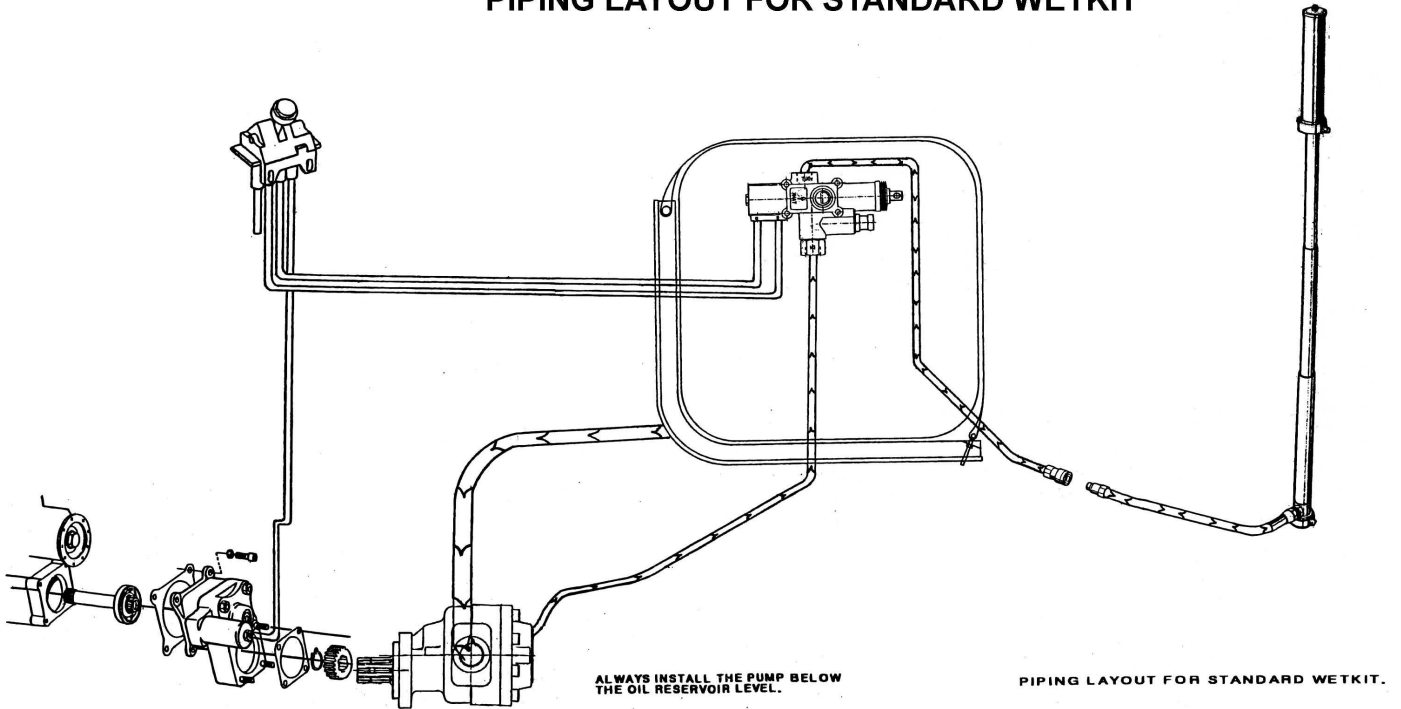

# M A I N T E N A N C E I N S T R U C T I O N

Periodic maintenance and inspection will increase the working life of the Tipping hoist. Follow the routine of the check list set out below at least **once per week** or every **50 cycles** whichever ever is sooner to ensure efficiency and safety of the tipping gear.

**Liberally** grease all grease points on the tipping gear and rear hinge.

Check all high pressure pipes and connections for oil leaks.

Check oil level in tank when Tipping hoist is at rest. Top up if necessary using the following:-

Recommend hydraulic oil:- Elf - Hydrelf 68. Morris - Triad HV37a. Texaco - Rando HD268.  
Shell - Tellus 68.

Check fixing bolts for damage and tightness.

Check vehicle for any form of damage or wear and take measures to fully repair or replace damage on the vehicle.

Replace any damaged tipping gear parts immediately with genuine HARSH replacements.

# S A F E T Y I N S T R U C T I O N

## While Tipping.

Always check for overhead wires, obstructions and make sure that no other people are in the vicinity of the vehicle or tipping area before tipping.

Tip with the vehicle at rest , on level ground and with a balanced even load.  
(Never overload, or heap the load).

Always check the conditions of the area where tipping i.e. do not tip when there is:

Wet or unstable ground which may collapse or in high winds.

Stay in cab when Tipping. If the load sticks or any problems develop immediately lower the body.  
(Never shunt load free or leave cab and go under a raised loaded body.)

After tipping, always lower the body fully before driving off and disengage PTO.

## While Working on Vehicle.

Never work under a raised loaded body even if propped.

Never work under a raised empty body unless propped.

Look for any signs of wear not only on the tipping gear but also the wood packers, hinge assembly, hoses, valve and tank assembly.

**NEVER ALLOW ANYONE UNDER AN UNPROPPED BODY**

# THE HARSH RIGID LIFT HOIST 3-YEAR LIMITED WARRANTY

HARSH LTD. warrants each new HARSH Hydraulic Tipping Gear main frame assembly to be free from defects in material and workmanship for a period of three years from the date of *despatch*. Harsh Ltd. warrants the hydraulic cylinders to be free from defect in material and workmanship for a period of one year. This warranty is expressly made to the *Original Owner* and is limited to the *Original Chassis* upon which the HARSH Rigid Lift Tipping Gear is installed.

Warranties do not extend to any Tipping Gear unit or part thereof which has been subjected to misuse, neglect, accident, improper installation, or loading over and above the recommended weight range. This warranty does not extend to such tipping gear units or parts which have been repaired or altered outside of our Factory, or to which any accessories other than HARSH have been affixed, or to any Tipping Gear not installed by an authorised HARSH Dealer or Distributor.

Harsh Ltd.'s obligation under this warranty is limited to replacement or repair of any part or parts thereof, which within the warranty period shall be returned to our factory, at Full Sutton, transportation charges pre-paid, for inspection. If such inspection reveals that a defect in material or manufacturing actually exists, then Harsh Ltd., at its option, may repair or replace the defective part. All items not manufactured at Harsh Ltd.'s Full Sutton base are subject to the original manufacturer's warranty.

This warranty is not valid until the warranty validation certificate form (which is attached and provided at the time of purchase and installation) is completed by the purchaser and returned to Harsh Ltd. Harsh Ltd. does not assign to any of its Dealers, Distributors, or Agents the right of warranty on its behalf. If said Dealer or Distributor in performing a service or repair, returns to our factory on behalf of the purchaser such parts or tipping gear the existence, validity or applicability of this warranty regarding such part or tipping gear remains solely the prerogative of Harsh Ltd. and not its aforementioned Agents. HARSH tipping gear units are intended to be used on trucks dumping from firm and level ground. Use of the tipping gear for purposes not recommended is at the purchaser's own risk. Any use of the tipping gear for a purpose or in a manner contrary to the recommendations set forth above in these paragraphs shall void the provisions of this warranty.

This warranty goes into effect on the above units installed 1/8/88 or later.

**Harsh Ltd.**  
**The Industrial Estate**  
**Full Sutton,**  
**York YO4 1HS**

7-1-87 **Retain this part of form for your records. Mail lower part of form to Harsh Ltd. as per instructions.**

## HARSH WARRANTY VALIDATION CERTIFICATE

**TO VALIDATE YOUR WARRANTY:** Complete this form and return it to Harsh Ltd. at the above address.

**NOTE:** Failure to complete and return this form within 30 days from date of installation as prescribed invalidates any warranty obligation by Harsh Ltd.

YOUR NAME & ADDRESS.....  
 ..... Tel. No. ....

HARSH DEALER'S NAME & ADDRESS .....

TIPPING GEAR MODEL..... SERIAL NO. ....

TRUCK CHASSIS MODEL ..... CHASSIS SERIAL NO. ....

DATE INSTALLED ..... INSTALLED BY .....

HOW DID YOU FIND OUT ABOUT HARSH PRODUCTS?

Magazine  Mail  Harsh Owner  Exhibition  Body Builder  Truck Dealer  Other (please state) .....

TYPE OF USAGE ..... COMMODITIES HAULED .....

CONDITION AND / OR APPEARANCE WHEN PURCHASED .....

BODY USED: MFG NAME ..... LENGTH ..... SIDE HEIGHT .....

PRICE PAID FOR TIPPING GEAR ..... PRICE PAID FOR INSTALLATION .....

OTHER REMARKS .....

*I have read and fully understand the provisions and limitations of this warranty as outlined above.*

SIGNED ..... DATE .....